

Memorex®

Is it live or is it Memorex?™

MKA381

User's Guide

Wireless Microphone

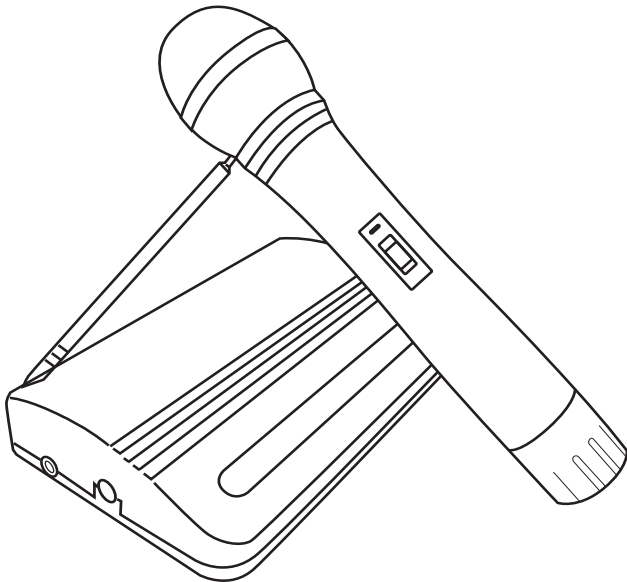

**Before operating this product,
please read these instructions completely.**

SAFETY PRECAUTIONS

FCC INFORMATION

Warning: Modifying, tampering and/or adjusting this unit or replacement of any transmitter component (crystal, semiconductor, etc.) in this unit could result in a violation of the rules.

FCC NOTICE

This wireless microphone system complies with Part 90 of FCC Rules. There are two frequencies available for the system. You must get a license for each frequency you plan to use before you use the system (one license can include both frequencies). Visit <http://wireless.fcc.gov/uls/> to access the license online or phone the nearest FCC offices and contact them to get the necessary application. Licensing depends on how you will use the system.

RF EXPOSURE

This wireless microphone contains a low power transmitter. When the power is on, it sends out radio frequency (RF) signals. In August 1996, the Federal Communications Commissions (FCC) adopted RF exposure guidelines with safety levels for wireless devices.

IMPORTANT NOTE: To adhere to the FCC RF exposure compliance requirements, no change to the antenna or the unit is permitted. Any change to the antenna or the unit could result in the system exceeding the RF exposure requirements.

IMPORTANT

To maintain compliance with the FCC's RF exposure guidelines hold the transmitter and antenna at least 1 inch (2.5 centimeters) from your face and speak in a normal voice, with the antenna pointed up and away from your face. Ensure that the antenna is at least 1 inch (2.5 centimeters) from your body when using your wireless microphone.

Use only the supplied antenna. Unauthorized antennas, modifications or attachments could damage the transmitter and may violate FCC regulations.

SAFETY PRECAUTIONS (CONTINUED)

Warning: Changes or modifications to this unit not expressly approved by the party responsible for compliance could void the user's authority to operate the equipment.

NOTE: This equipment has been tested and found to comply with the limits for a Class B digital device, pursuant to Part 15 of the FCC Rules. These limits are designed to provide reasonable protection against harmful interference in a residential installation. This equipment generates, uses and can radiate radio frequency energy and, if not installed and used in accordance with the instructions, may cause harmful interference to radio communications. However, there is no guarantee that interference will not occur in a particular installation. If this equipment does cause harmful interference to radio or television reception, which can be determined by turning the equipment off and on, the user is encouraged to try to correct the interference by one or more of the following measures:

- Reorient or relocate the receiving antenna.
- Increase the separation between the equipment and receiver.
- Connect the equipment into an outlet on a circuit different from that to which the receiver is connected.
- Consult the dealer or an experienced radio/TV technician for help.

PLEASE KEEP ALL PACKAGING MATERIAL FOR AT LEAST 90 DAYS IN CASE YOU NEED TO RETURN THIS PRODUCT TO YOUR PLACE OF PURCHASE OR MEMOREX.

LOCATION OF CONTROLS

MICROPHONE

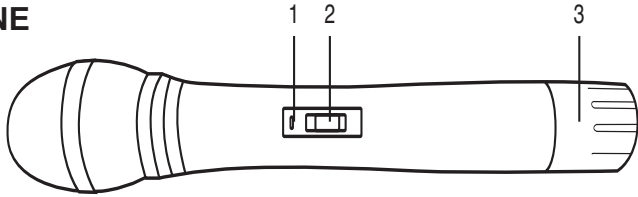

RECEIVER FRONT

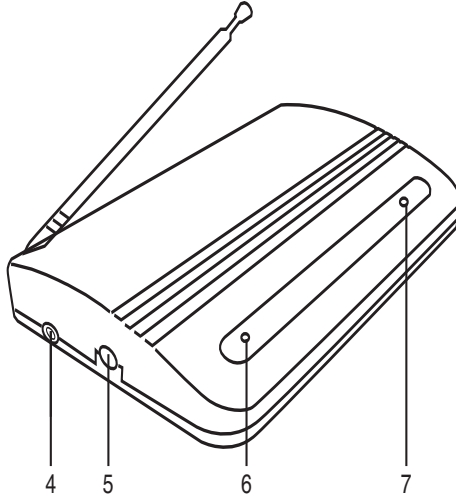

RECEIVER SIDE

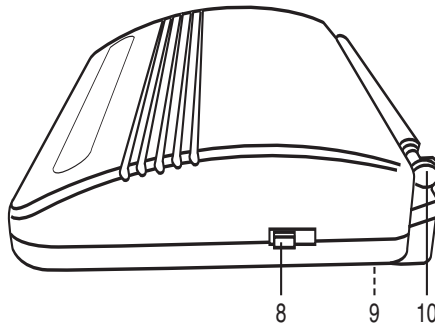

- | | |
|-------------------------------------|---|
| 1. POWER Indicator | 7. Microphone ON Indicator |
| 2. Microphone ON/STANDBY/OFF Switch | 8. POWER ON/OFF Switch |
| 3. Battery Compartment | 9. Battery Compartment (Bottom of Receiver) |
| 4. Line OUT Jack | 10. Antenna |
| 5. DC 9V Jack $\ominus \oplus$ | |
| 6. POWER ON Indicator | |

INSTALLATION

REPLACING THE BATTERIES

If the sound quality starts to become poor or the receiving distance has shortened, replace the batteries in the microphone and the receiver as follows:

INSTALLING THE BATTERY INTO THE MICROPHONE

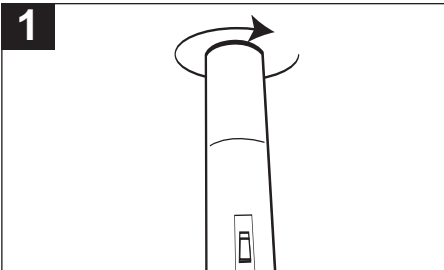

Remove the battery cover at the bottom of the microphone by twisting it counterclockwise.

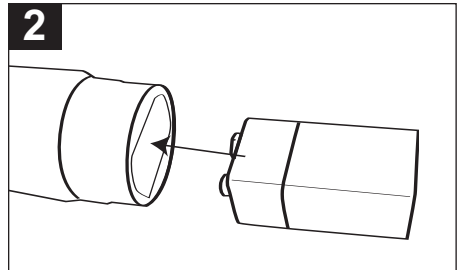

Insert one 9V battery, making sure to observe the correct polarity (+/-). Twist the battery cover clockwise to put it back on.

INSTALLING THE BATTERY INTO THE RECEIVER

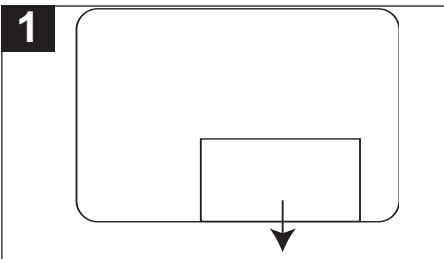

Remove the battery cover by sliding it off. To prevent the possibility of losing the cover, it cannot be removed.

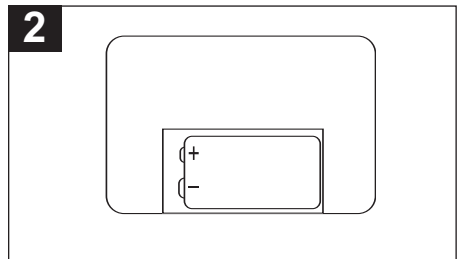

Insert a 9V size battery (not included) to the connector inside the battery compartment. Slide the battery cover back into place.

DC JACK  To use the receiver with AC power, connect the AC adapter (included) to an AC outlet having AC 120V, 60Hz only. Plug the small end into the DC 9V jack on the side of the unit and connect the other end into the AC outlet. The batteries will be disconnected when the AC adapter is connected.

BATTERY PRECAUTIONS

Follow these precautions when using batteries in this device:

1. Use only the size and type of batteries specified.
2. Be sure to follow the correct polarity when installing the batteries as indicated in the battery compartment(s). Reversed batteries may cause damage to the device.
3. If the device is not to be used for a long period of time, remove the batteries to prevent damage or injury from possible battery leakage.
4. Do not try to recharge batteries not intended to be recharged; they can overheat and rupture. (Follow battery manufacturer's directions.)

OPERATION

USING YOUR MICROPHONE (TRANSMITTING)

To use your microphone, please see the following:

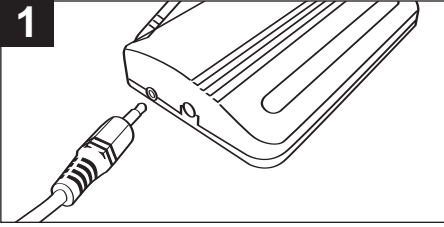

1 Insert the large end of the cord into the Microphone jack on the unit you are connecting this wireless microphone to and the small end into the Line OUT jack on the receiver.

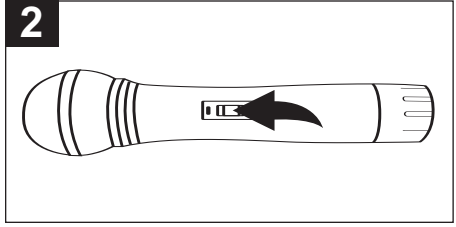

2 Slide the Microphone ON/STANDBY/OFF switch to the ON position; the POWER indicator on the microphone will light.

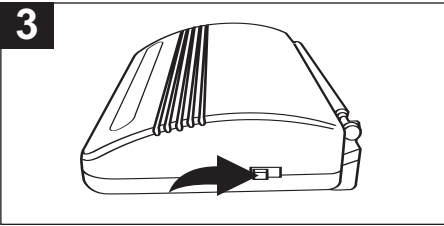

3 Slide the Receiver's POWER switch to the ON position; the red POWER indicator on the receiver will light. If the microphone is on, the green Microphone ON indicator on the receiver will also light. Raise the antenna for best reception and speak or sing into the microphone as desired.

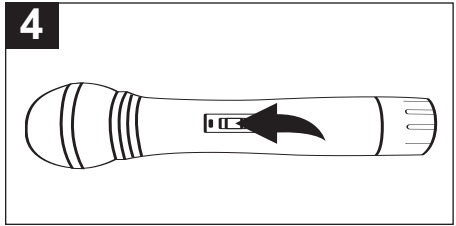

4 Slide the Microphone ON/STANDBY/OFF switch to the STANBY (Standby) position to put the microphone in Standby mode (it will be on, but will not transmit). Slide the Microphone ON/STANDBY/OFF switch to the OFF position to turn the microphone off; the POWER indicator on the mic and the green MIC indicator on the receiver will go out.

NOTES:

- When done using the receiver, slide the POWER switch to the OFF position; the red POWER indicator will go out.
- If your microphone is not to be used for a long period of time, remove the batteries in the microphone and the receiver.
- If the microphone is out of range (microphone too far away from the receiver) the green Microphone ON indicator on the receiver will turn off and the microphone will be muted.

SPECIFICATIONS

Power Requirement

ReceiverDC 9V Battery
Microphone.....DC 9V Battery

Frequency171.045MHz
Receive Distance.....7m

Specifications subject to change without notice.

**FOR ADDITIONAL SET-UP OR OPERATING ASSISTANCE, PLEASE VISIT OUR
WEB SITE AT**

WWW.MEMOREXELECTRONICS.COM

OR CONTACT CUSTOMER SERVICE AT (954) 660-7100.

**PLEASE KEEP ALL PACKAGING MATERIAL FOR AT LEAST 90 DAYS IN CASE
YOU NEED TO RETURN THIS PRODUCT TO YOUR PLACE OF PURCHASE OR
TO MEMOREX.**

**FOR PARTS AND ACCESSORIES, CONTACT FOX INTERNATIONAL AT
1-800-321-6993.**

Memcorp, Inc.
Weston, FL
Printed in Hong Kong

Visit our web site at www.memorexelectronics.com